

DC-DC CONVERTER HEC150-W, HFC150-W

RAILWAY CONVERTER.

FOR STANDARD EURO RACK SIZE 19" AND CHASSIS MOUNTING



HIGHLIGHTS

- + Output Power up to 150 Watts
- + Efficiency up to 91 %
- + Ultra Wide Input Range
- + Hold-up-time > 10ms
- + Redundant Operation
- + Wide Temperature Range
- + RoHS compliance
- + According to EN50155

INPUT

Input Voltage Nominal	24, 36, 48, 72, 96 and 110 VDC
Input Voltage Operating	16,8-137,5 VDC
Input Voltage Range	14,4-154 VDC (t ≤ 1,0 sec.) (Class C1)
No Load Input Current	See table page 2

OUTPUT

Output Voltage	24 V (other voltages on request)
Initial Set Accuracy	< 1 %*
Minimum Load	No minimum load
Short circuit	Continuous short circuit proof
Line Regulation	< 0,5 %
Load Regulation	< 1 % (0 % - 100 % load)
Ripple & Noise	< 1 % pk-pk, 20 MHz bandwidth*
Start Time	< 2 s
Max. Output Capacitance	500 uF x I _{out nom}
Temperature Coefficient	< 0.02 %/°C

FEATURES

Enable Signal	Switched to high level, the converter switches off. Open pin enables the converter.
Active Inrush Current Limitation	Max. 16 A (at t > 100 us) < 1,0 A ² s
Active Reverse Polarity Protection	Max. 160 V
Hold-up-time	> 10 ms at full load (V _{out nom} ± 4% at Vin = 24...72 V, ± 1 % at Vin = 96...110 V)
Yellow LED	To indicate operating mode
Thermal Warning Signal	Isolated open-collector output. Active level: Low when the case reaches the temperature of 5 - 10 °C below the OTP.
Power Good Signal	Isolated open-collector output. Active level: Low when output voltage is over 80 % of V _{out nom}
Redundant Operation	The breakdown of a converter will be monitored by the Power Good Signal

* For T_{amb} = 25 °C, V_{in nom}, I_{out nom}

** +70 °C continuously, +85 °C max. 10 minutes at full load

*** In built-in condition our devices may show different EMC properties

**** The output switches-off when V_{out nom} < 70 % and restarts automatically latest after 1 s of elimination of the overload.

PROTECTION

Over Voltage Protection (OVP)	110-130 % V _{out nom}
Over Current Protection (OCP)	I _{out nom} > 105
Over Temperature Protection (OTP)	Shutdown at +105 - 110 °C case-temp. with approx. 5 °C hysteresis and auto recovery.

GENERAL

Product Standard	EN 50155:2017
Isolation	2200 VDC Input to Output 1500 VDC Input to Baseplate 750 VDC Output to Baseplate
Pollution Degree	PD2 according to EN 50124-1:2017
Switching Frequency	Typ. 120 kHz
Dimensions [mm]	See mechanical details page 3
Weight	HEC150-W (approx.): 625 g / HFC150-W: 825 g
MTBF	TBD
Fire & Smoke	EN 45545-2:2016-02 HL3 (R25)

ENVIRONMENTAL

Operating Ambient Temp.	-40 °C to +85 °C** (Class OT4 + ST1, ST2)
Storage Temperature	-40 °C to +85 °C
Rapid Temperature Variation	Class H1
Attitude	up to 2000m
Vibration / Shock / Bump	EN 61373:2010, Cat. 1B

EMC & SAFETY

EMC Standard	EN 50121-3-2:2016
Emissions	EN 55011:2016+A1:2017, Class A***
ESD Immunity	EN 61000-4-2:2009, level 3 (6kV/8kV), Criteria A
Burst	EN 61000-4-4:2012, level 3 (2kV), Criteria A
Surge	EN 50121-3-2:2016, line to line ±1kV, 42R, and line to case ±2kV, 42R, Criteria A EN 61000-4-5:2014+A1:2017, line to line ±0,5kV, and line to case ±1kV, Criteria A
Radiated Immunity	EN 61000-4-3:2006+A1:2008+A2 2010, 20V/m, Criteria A
Safety	IEC 62368-1:2014 (second edition)

DESCRIPTION OF FEATURES

For $T_{amb} = 25^{\circ}\text{C}$, $V_{in\ nom}$, $I_{out\ nom}$, unless otherwise specified

SPECIFICATION Input 14,4 - 154 VDC

TYPE		HEC150-W / HFC150-W						
ORDER NUMBER		87 45 24 0112 5 / 87 46 24 0112 1						
CHARACTERISTIC		Unit						
INPUT	Input Voltage Nominal	V	24	36	48	72	96	110
	Input Voltage Range	V	14,4...36	21,6...51	28,8...67,2	43,2...101	57,6...134,4	66...154
	Under Voltage Turn-on	V	<15,0...16,8					
	Under Voltage Turn-off	V	<12,0...14,4 (14,4V < V_{in} < 16,8V at $t > 1$ sec.)					
	Input Current @ Full Load	A	6,9	4,5	3,4	2,2	1,7	1,5
	Input Current @ No Load	A	0,09	0,07	0,06	0,04	0,04	0,03
	Internal Fuse	A	16					
OUTPUT	Output Voltage Nominal	V	24					
	Output Current Nominal	A	6,25					
	Output Power	W	150					
	Efficiency @ Full Load (typical)	%	89	90	91	91	90	90
	Short Circuit Current (typical)	A	30 (pulse approx. 1Hz)*					
	Transient Response 25 % / 75 % Load Step Recovery Time < 1 ms	mV	± 200					

* Peak current pulsating

TECHNICAL DATA

For $T_{amb} = 25^{\circ}\text{C}$, $V_{in nom}$, $I_{out nom}$, unless otherwise specified

MECHANICAL DETAILS

1. Dimensions are in mm
2. Unless otherwise specified, general tolerances $\pm 0,5$ are for values in brackets (XX).
Values not in brackets are according to ISO 2768-1m.

Coating: Lackwerke Peters ELPEGUARD SL 1307-FLZ/2
Protection Degree: IP20

HEC150-W:

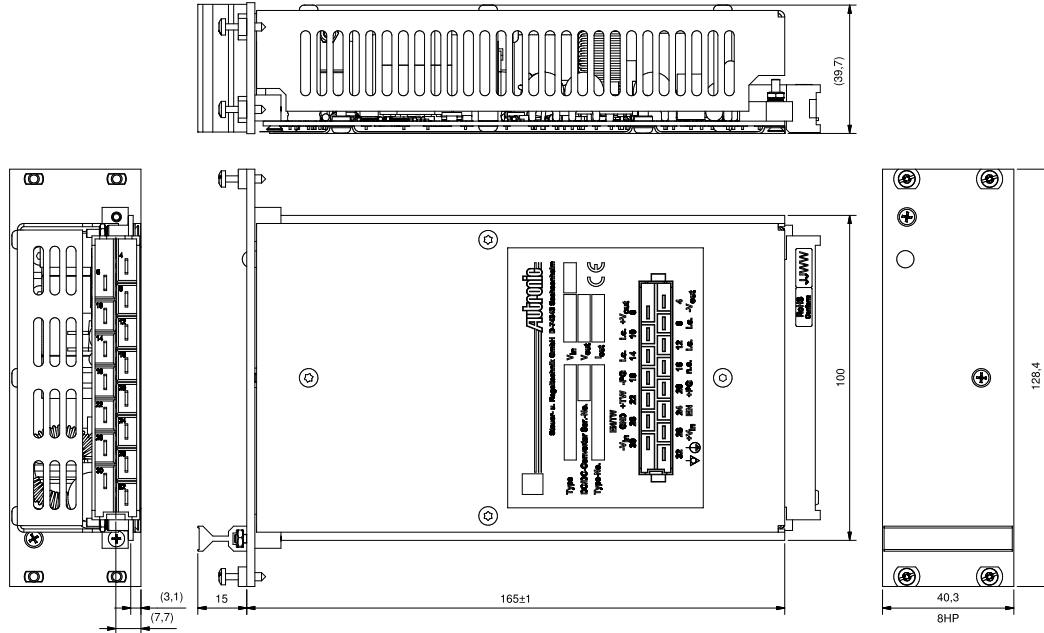

HFC150-W:

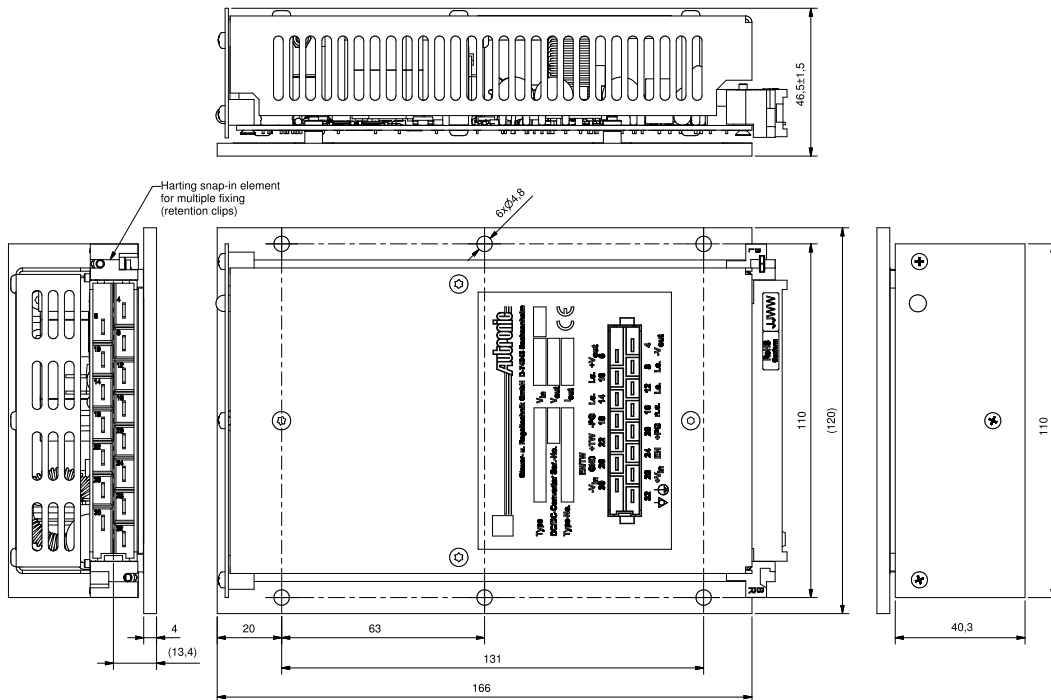

Production acc. to IPC-A-610 (exception bonding)

DESCRIPTION OF FEATURES

For $T_{amb} = 25^{\circ}\text{C}$, $V_{in\ nom}$, $I_{out\ nom}$, unless otherwise specified

PINNING

Pin	Function	Pin	Function
4	$-V_{out}$ Negative Output Voltage	20	+PG +Power Good
6	$+V_{out}$ Positive Output Voltage	22	+TW +Thermal Warning
8	i.c. Internal connected	24	EN Enable Signal
10	i.c. Internal connected	26	EN/TW Enable and Thermal Warning Ground
12	i.c. Internal connected	28	$+V_{in}$ Positive Input Voltage
14	i.c. Internal connected	30	$-V_{in}$ Negative Input Voltage
16	i.c. Internal connected	32	Case Potential of the case
18	-PG -Power Good		

NOTES

Installation Instructions:

The converters have to be installed according to the guidelines currently in force, like other open electronic component assemblies. Attention must be paid to sufficient ventilation, carry off heat, fastening and protection against accidental contact. Plug in not under voltage if converter connected parallel or in series. The mounting surface must be flat and able to remove the thermal energy of the baseplate. The pin 32, case: (∇ / \oplus), has to be properly connected to Chassis/Earth in order to assure operation.

Internal Fuse:

The converter is equipped with a soldered-in-time-lag fuse corresponding to IEC 60127-2 for input protection. In case of fault the supplying current source must be capable to blow the fuse.

BLOCK DIAGRAM

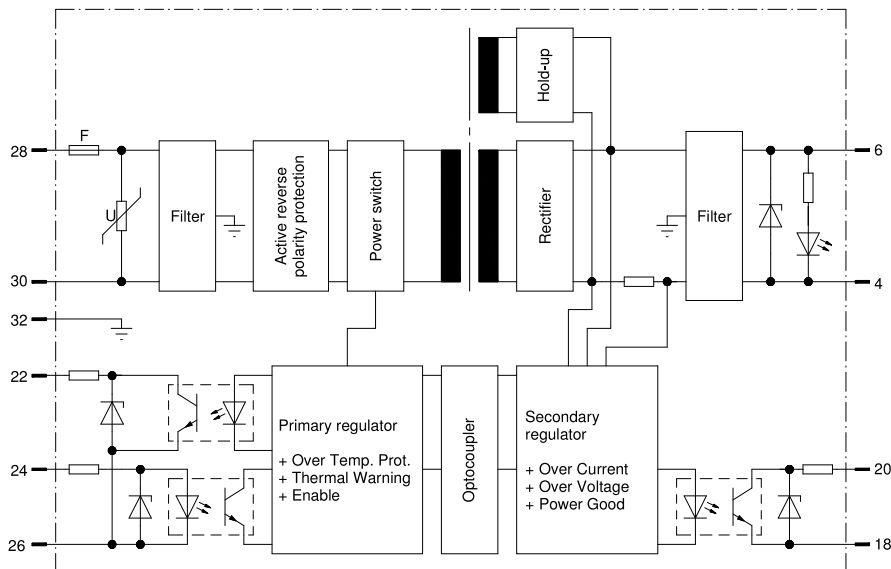

DESCRIPTION OF FEATURES

For $T_{amb}=25^{\circ}\text{C}$, $V_{in\ nom}$, $I_{out\ nom}$, unless otherwise specified.

ENABLE SIGNAL

The Enable signal is a potential-free input signal realized by an optocoupler. Input current: from 1,0 mA min to 5,0 mA max.

The converter is on, when Enable input voltage is 0..0,8 V or is not connected.

If the Enable signal is switched to high level >3,3V then the converter switches off.

This may be done with an external control voltage (V1).

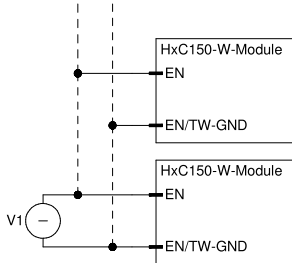

If a potential-free Enable signal is not required, then EN/TW-GND (Pin 26) can be connected to -Vin (Pin 4).

When not in use, leave Enable pin not-connected.

THERMAL WARNING SIGNAL

The Thermal Warning is a potential-free Open-Collector Output realized by an optocoupler. Current $\leq 1\text{ mA}$, Voltage < 10 V, saturation voltage < 0,8 V.

The signal becomes active (LOW) when the temperature of the PCB rises above typ. 95°C , with a hysteresis of about 5°C .

When not in use, leave Thermal Warning pin not-connected.

POWER GOOD SIGNAL

The Power Good is a potential free Open-Collector Output realized by an optocoupler. Current $\leq 1\text{ mA}$, Voltage < 10 V, saturation voltage < 0,8 V.

The signal becomes active when the output voltages are above 80 % of $V_{out\ nom}$.

When not in use, leave Output Power Good pins not-connected.

REDUNDANT OPERATION

For redundant operation two converters can be connected in parallel.

The nominal load of a single converter must not exceeded.

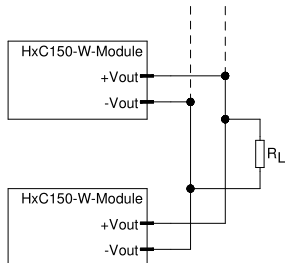

CHANGE HISTORY

Revision	Date	Author	Modification
a02	2021-03-23	Ehrhardt	Change for new Product Standard EN50155:2017