

DC-DC CONVERTER HFC50-W

RAILWAY CONVERTER.

FOR CHASSIS MOUNTING



HIGHLIGHTS

- + Output Power up to 50 Watts*
- + Efficiency up to 92%
- + Ultra Wide Input Range
- + Wide Temperature Range
- + Hold-up-time > 10ms
- + RoHS compliance
- + According to EN50155

INPUT

Input Voltage Nominal	24, 36, 48, 72, 96 and 110 VDC
Input Voltage Operating	16,8-137,5 VDC
Input Voltage Range	14,4-154 VDC (t ≤ 1,0 sec.)
No Load Input Current	See table page 2
Internal Fusing	5,0 AT

OUTPUT

Output Voltage	12 V, 24 V
Initial Set Accuracy	< 2 %
Minimum Load	No minimum load
Short circuit	Continuous short circuit proof
Line Regulation	< 0,5 %
Load Regulation	< 1 % (0% - 100% load)**
Ripple & Noise	< 1 % pk-pk, 20 MHz bandwidth
Start Time	< 1,5 s
Max. Output Capacitance	500 µF x I _{out nom}
Temperature Coefficient	< 0.01 %/°C

FEATURES

Active Reverse Polarity Protection	Max. 160 V
Active Inrush Current Limitation	Max. 8 A (for ≥ 0,5ms)
Hold-up-time	> 10 ms at full load (V _{out nom} ± 4% at V _{in} = 24...72V, ± 1% at V _{in} 96...110V)
Parallel operation	Up to 3 converters can be connected in parallel operation.

* +70°C continuously, +85°C max. 10 minutes. With additional thermal conductive pad between PCB and heat sink mounting surface at free convection in vertical position.

** In built-in condition the devices may show different EMC properties.

*** Value could be higher, depending on the voltage drop of the connector.

PROTECTION

Over Voltage Protection (OVP)	115-125 % V _{out nom} . The output switches-off and restarts after 500 ms time.
Over Current Protection (OCP)	I _{out nom} > 105%. The output switches-off when V _{out nom} < 90% and restarts automatically latest after 500 ms of elimination of the overload.
Over Temperature Protection (OTP)	Shutdown at +100-105°C PCB-temp or +95°C-100°C Case-temp. with about 5°C hysteresis and auto recovery.

GENERAL

Product Standard	EN 50155:2007
Isolation	2200 VDC Input to Output 1500 VDC Input to Earth (PE) 710 VDC Output to Earth (PE)
Switching Frequency	Typ. 125 kHz
Dimensions [mm]	HFC50-W/O: 100 x 80 x 28 HFC50-W/G: 124 x 88 x 33,5
Weight	HFC50-W/O: 160g HFC50-W/G: 285g
MTBF	2.483.651h acc. to IEC/TR 62380 (45°C) 1.704.417h acc. to IEC/TR 62380 (60°C)
Fire & Smoke	EN 45545-2:2016-02 HL3 (R25)

ENVIRONMENTAL

Operating Ambient Temp.	-40°C to +85°C* (Class TX)
Operating PCB Temp.	-40°C to +100°C
Storage Temperature	-40°C to +85°C
Altitude	up to 2000m
Vibration / Shock / Bump	EN 61373:2010, Cat. 1B

EMC

EMC Standard	EN 50121-3-2:2016
Conducted Emissions	EN 55011:2009+A1:2010, Class A**
Radiated Emissions	EN 55011:2009+A1:2010, Class A**
Burst	EN 61000-4-4:2012, level 3 (2kV), Criteria A
Surge	EN 50121-3-2:2015, line to line ±1kV, 42R, and line to case ±2kV, 42R, Criteria A EN 61000-4-5:2014, line to line ± 0,5kV and line to PE ± 1,0kV, Criteria A
Conducted Immunity	EN 61000-4-6:2014, level 3 (10V), Criteria A
Radiated Immunity	EN 61000-4-3:2006+A1:2008+A2:2010, 20V/m, Criteria A
Safety	EN 62368-1:2014 (second edition)

TECHNICAL DATA

For $T_{amb} = 25^{\circ}\text{C}$, $V_{in\ nom}$, $I_{out\ nom}$ unless otherwise specified

SPECIFICATION Input 14,4 - 154 VDC

		HFC50-W/O / HFC50-W/G						
		87 66 12 0112 4 / 87 66 12 0115 7						
CHARACTERISTIC		Unit						
INPUT	Input Voltage Nominal	V	24	36	48	72	96	110
	Input Voltage Range	V	14,4...36	21,6...51	28,8...67,2	43,2...101	57,6...134,4	66...154
	Under Voltage Turn-on		<15,0...16,8					
	Under Voltage Turn-off	V	<12,0...14,4 (14,4V < Vin < 16,8V at t > 1 sec.)					
	Input Current @ Full Load	A	2,35	1,56	1,17	0,77	0,58	0,5
	Input Current @ No Load	A	0,030	0,025	0,020	0,015	0,010	0,010
	Internal Fuse	A	5					
				Output				
OUTPUT	Output Voltage Nominal	V	12					
	Output Current Nominal	A	4,2					
	Output Power	W	50					
	Efficiency @ 30W Load (typical)	%	90	90	90	90	90	90
	Efficiency @ 50W Load (typical)	%	89	89	90	91	90	90
	Output Current limit	A	4,65...5,4					
	Short Circuit Current (typical)	A	9...18 (pulse approx. 2 Hz)*					
	Transient Response 25 % / 75 % Load Step Recovery Time < 1 ms	mV	±120					

SPECIFICATION Input 14,4 - 154 VDC

		HFC50-W/O / HFC50-W/G						
		87 66 24 0112 9 / 87 66 24 0115 3						
CHARACTERISTIC		Unit						
INPUT	Input Voltage Nominal	V	24	36	48	72	96	110
	Input Voltage Range	V	14,4...36	21,6...51	28,8...67,2	43,2...101	57,6...134,4	66...154
	Under Voltage Turn-on		<15,0...16,8					
	Under Voltage Turn-off	V	<12,0...14,4 (14,4V < Vin < 16,8V at t > 1 sec.)					
	Input Current @ Full Load	A	2,31	1,53	1,15	0,77	0,58	0,5
	Input Current @ No Load	A	0,030	0,020	0,020	0,015	0,010	0,010
	Internal Fuse	A	5					
				Output				
OUTPUT	Output Voltage Nominal	V	24					
	Output Current Nominal	A	2,1					
	Output Power	W	50					
	Efficiency @ 30W Load (typical)	%	90	90	90	90	90	90
	Efficiency @ 50W Load (typical)	%	90	91	92	92	91	91
	Output Current limit	A	2,4...2,9					
	Short Circuit Current (typical)	A	6...17 (pulse approx. 2 Hz)*					
	Transient Response 25 % / 75 % Load Step Recovery Time < 1 ms	mV	±160					

* Pulsating current time duration 50 ms

TECHNICAL DATA

For $T_{amb}=25^{\circ}\text{C}$, $V_{in\ nom}$, $I_{out\ nom}$ unless otherwise specified

MECHANICAL DETAILS

- Dimensions in mm
- Unless otherwise specified, general tolerances $\pm 0,5$ are for values in brackets (XX)
Values not in brackets are according to ISO-2768-1m.

Coating: Lackwerke Peters ELPEGUARD SL 1307-FLZ/2

Protection Degree: HFC50-W/O - IP00
HFC50-W/G - IP20

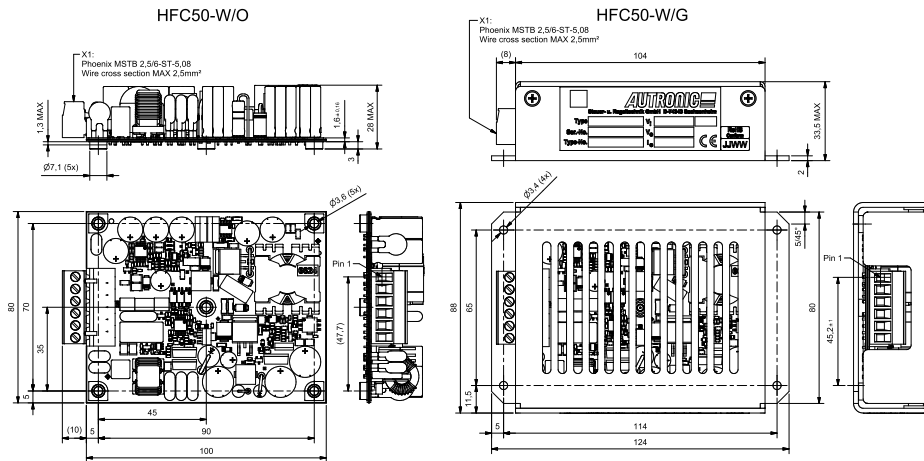

Production acc. to IPC-A-610 (exception bonding)

PINNING

Pin	Function	
X1-1	$-V_{out}$	Negative Output Voltage
X1-2	$+V_{out}$	Positive Output Voltage
X1-3	TR	Tracking
X1-4	$+V_{in}$	Positive input Voltage
X1-5	$-V_{in}$	Negative Input Voltage
X1-6	PE	Potential of the earth

NOTES

Installation instructions:

The converters have to be installed according to the guidelines currently in force, like other open electronic component assemblies. Attention must be paid to sufficient ventilation, carry off heat, fastening and protection against accidental contact. Additional thermal conductive pad might be necessary to get a thermal coupling to the mounting-surface. The mounting surface must be flat and able to remove the thermal energy of the PCB (PCB temperature must not exceed $+100^{\circ}\text{C}$).

The connection to earth/chassis ground has to be done by the 4 outer mounting holes or the pin 6 PE (∇ / \oplus).

Fault protection: The converters are equipped with a soldered-in-time-lag fuse corresponding to IEC 60127-2 for input protection. In case at fault the supplying current source must be capable to blow the fuse.

Caution for HFC50-W/O:

- No protection against touching, dangerous voltage
- After power off, wait 10 s before disconnecting or touching

BLOCK DIAGRAM

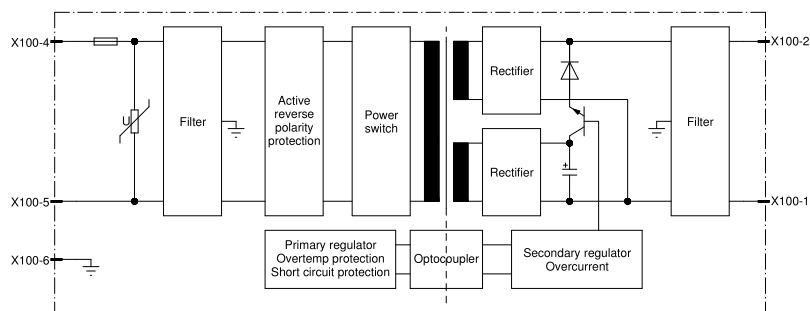

AUTRONIC
A FORTEC GROUP MEMBER

APPLICATION NOTES

THERMAL PADS

Recommendation: Soft gap-pads with a thermal conductivity of $> 2,5 \text{ W/mK}$, example: HALA TGF-MSS4000-Si

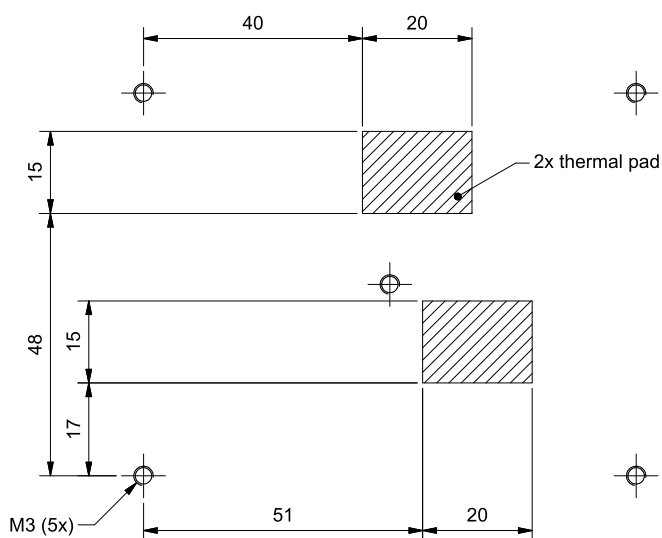
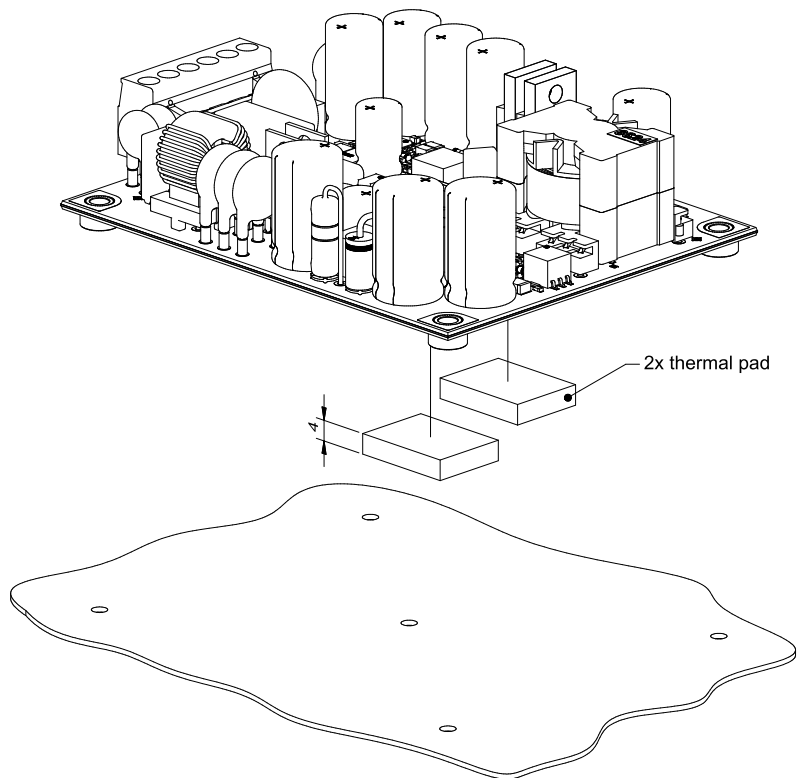

To avoid a mechanical deformation of the printed circuit board, please fasten the middle screw first.

DESCRIPTION OF FEATURES

PARALLEL OPERATION

Module of the same output voltage can be connected in parallel operation.

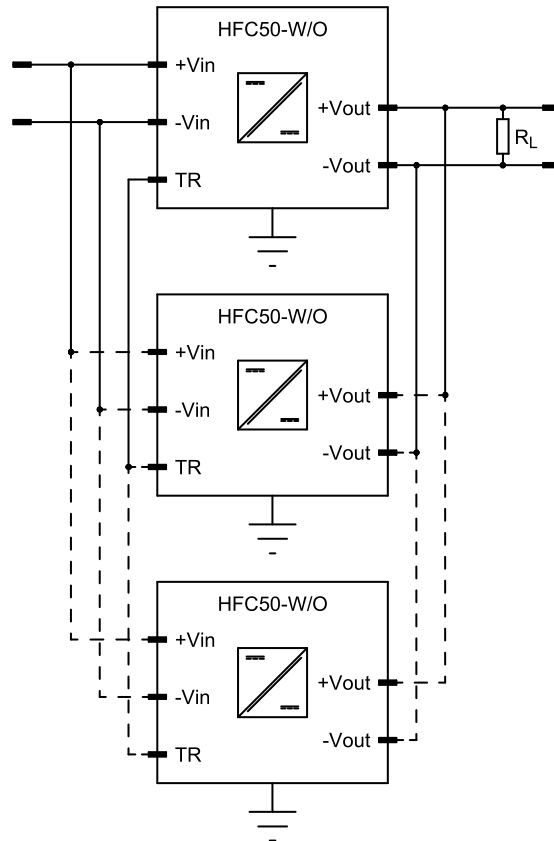

Connection signal TR should be as short as possible (max. 20 cm).
When not use parallel operation, leave Tracking pin not-connected.